

Typical Top Fuel Ignition System

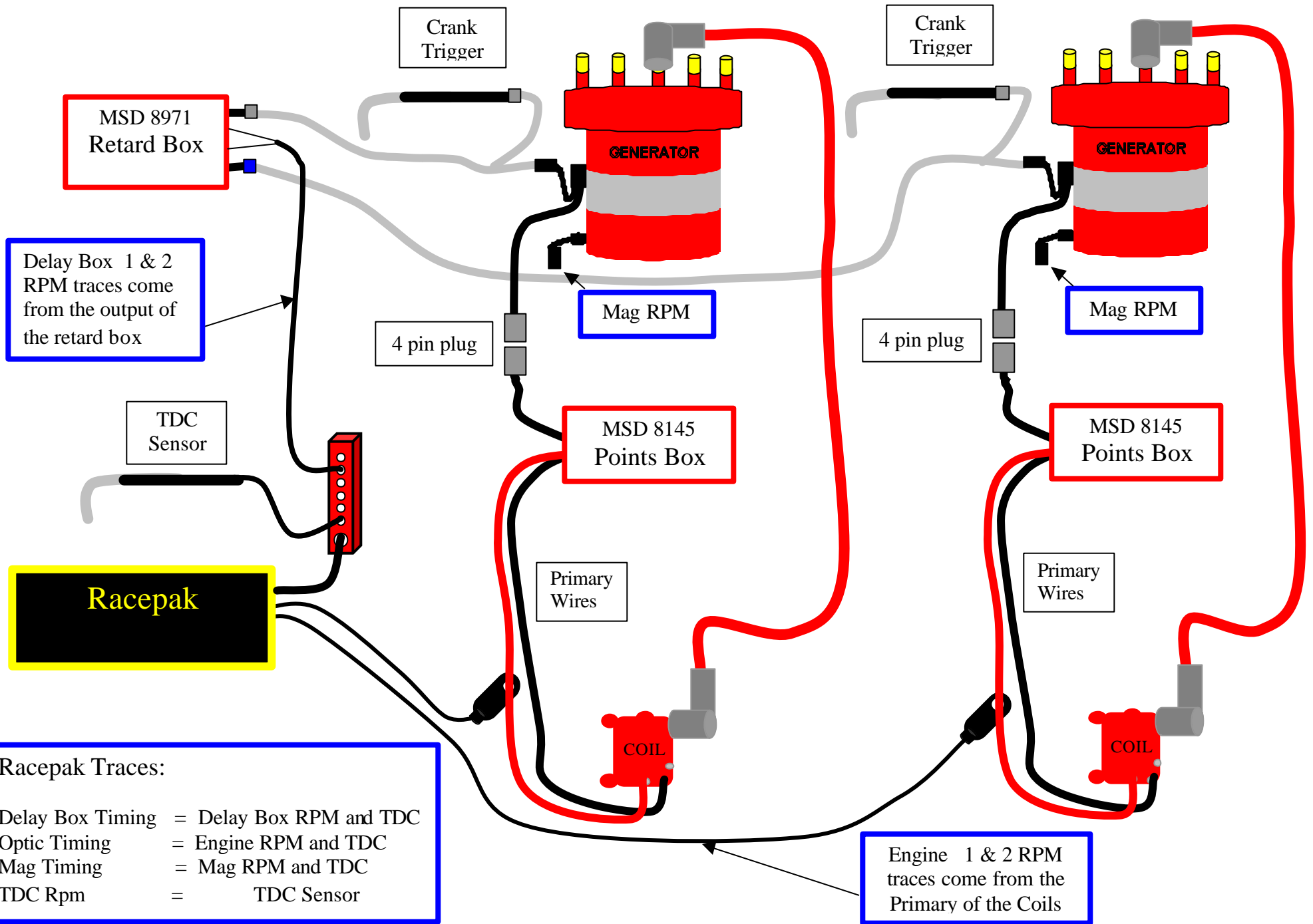

Racepak Traces:

Delay Box Timing	=	Delay Box RPM and TDC
Optic Timing	=	Engine RPM and TDC
Mag Timing	=	Mag RPM and TDC
TDC Rpm	=	TDC Sensor

Engine 1 & 2 RPM traces come from the Primary of the Coils